

XINJE

DS5E/DS5L

WUXI XINJE ELECTRIC CO., LTD.

Data No. SC5 04 20190429 2.1

1 Selection of servo syste

1.1 Selection of servo drive

1.1.1 Model name

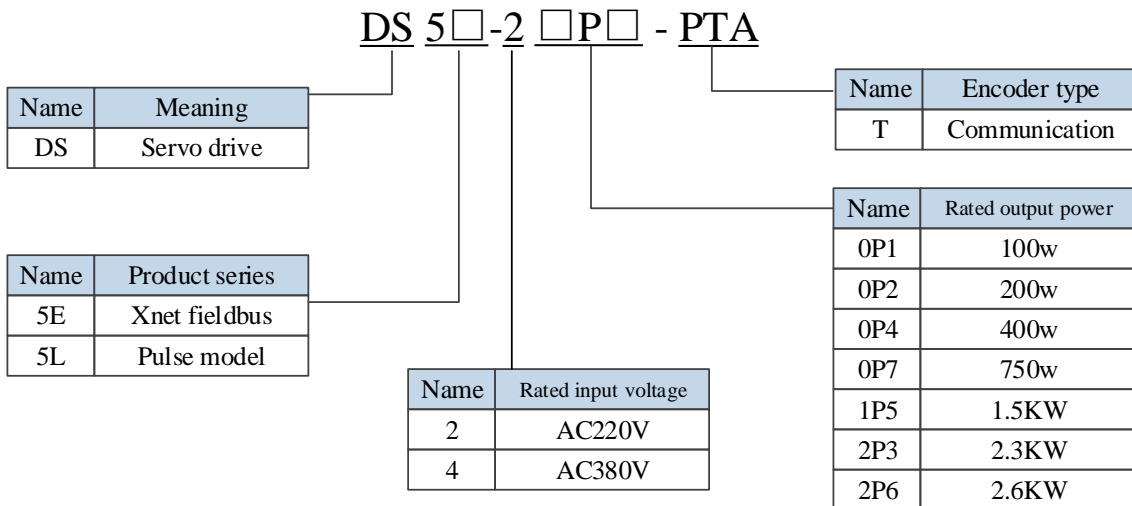

1.1.2 Description of each part

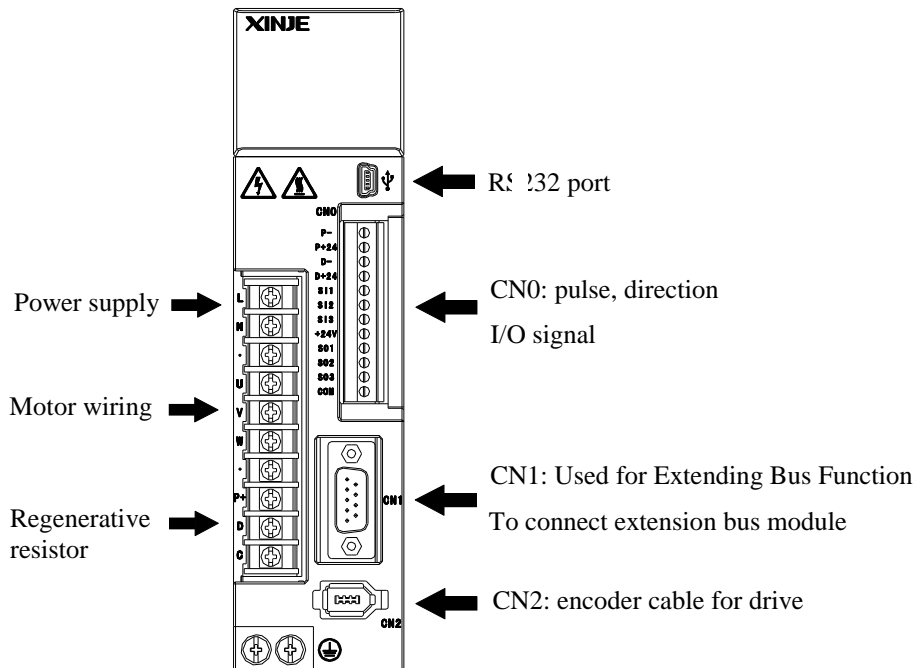

1.1.3 Performance specifications

Servo unit	DS5 series servo drive	
Applicable encoder	Standard: 17-bit/23-bit communication encoder	
Input power supply	DS5□-2□P□-PTA: Single/three phases AC200-240V, 50/60Hz Single phase AC200-240V 50/60Hz is used below 1.5KW (excluding 1.5KW); It is recommended to use three-phase AC200-240V 50/60Hz when the value is above 1.5KW (including 1.5KW). (For the single-phase power supply, please connect to L1 and L3, otherwise the power failure will affect the memory of parameters.)	
	DS5□-4□P□-PTA: three-phase AC340~420V, 50/60Hz	
Control mode	Three-phase full-wave rectifier IPM PWM control sinusoidal current drive mode	
Using condition	Using temperature	-10~+40 °C
	Storage temperature	-20~+60 °C
	Environment humidity	Below 90%RH (no condensation)
	Vibration resistance	4.9m/s ²
Structure	Pedestal installation	

1.2 Servo motor selection

1.2.1 Model name

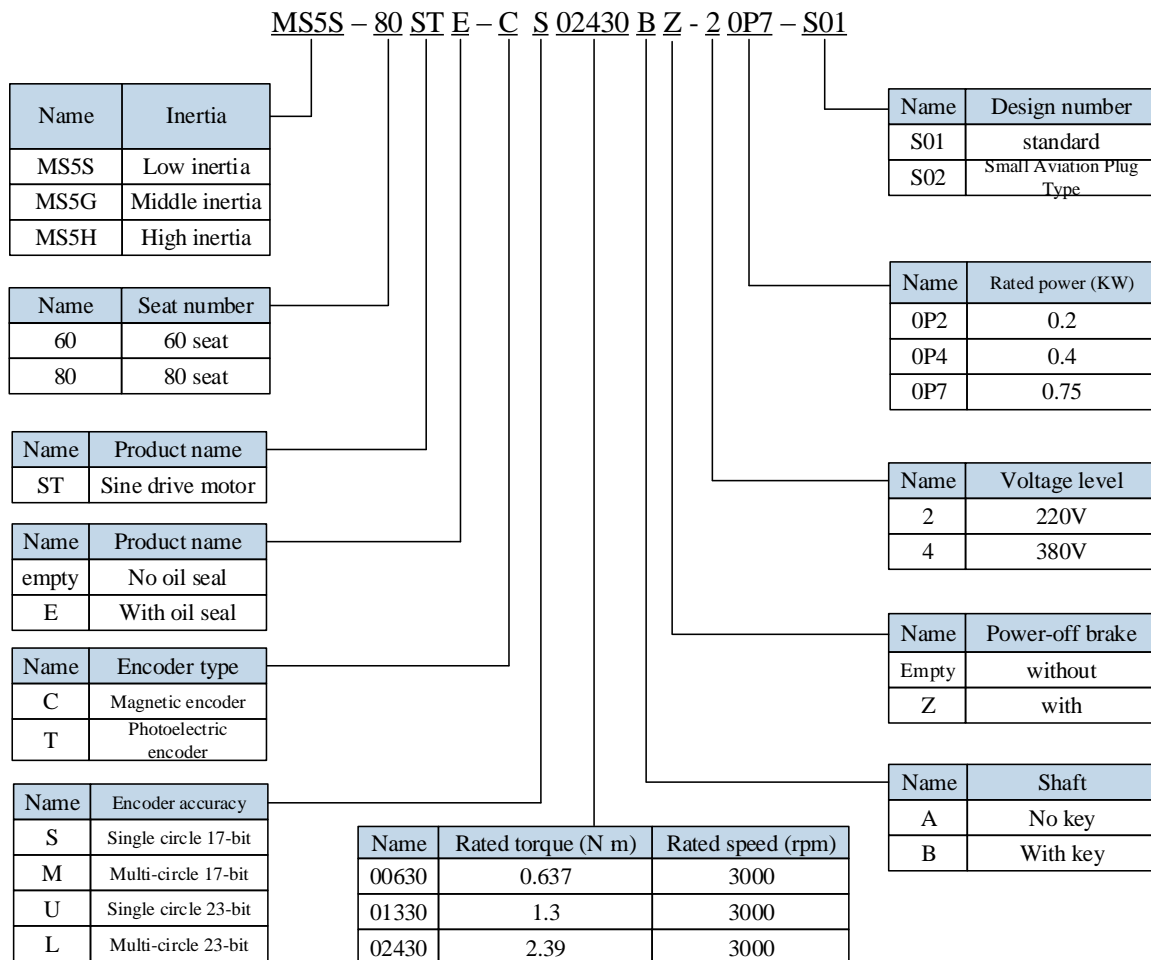

Note: At present, only the combination of CS, CM, TL and T is selected for the type of encoder.

1.2.2 Description of each part

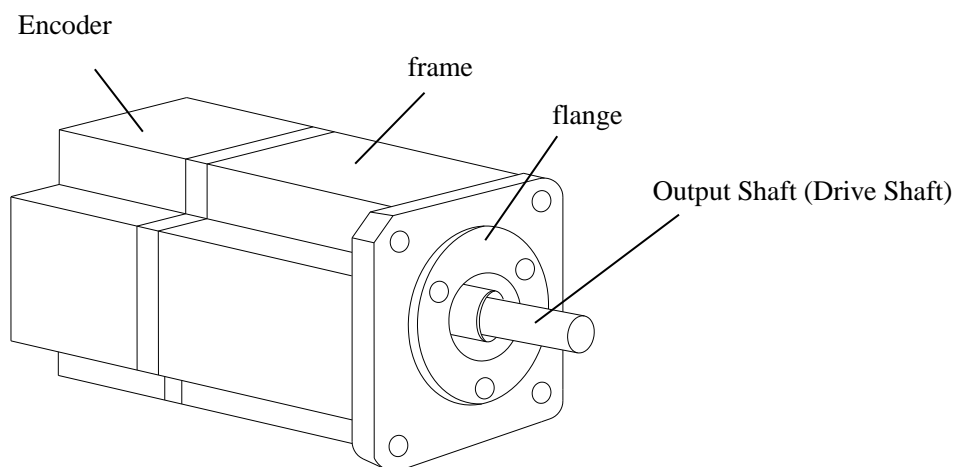

1.3 Cable selection

1.3.1 Model name

■ Encoder cable model

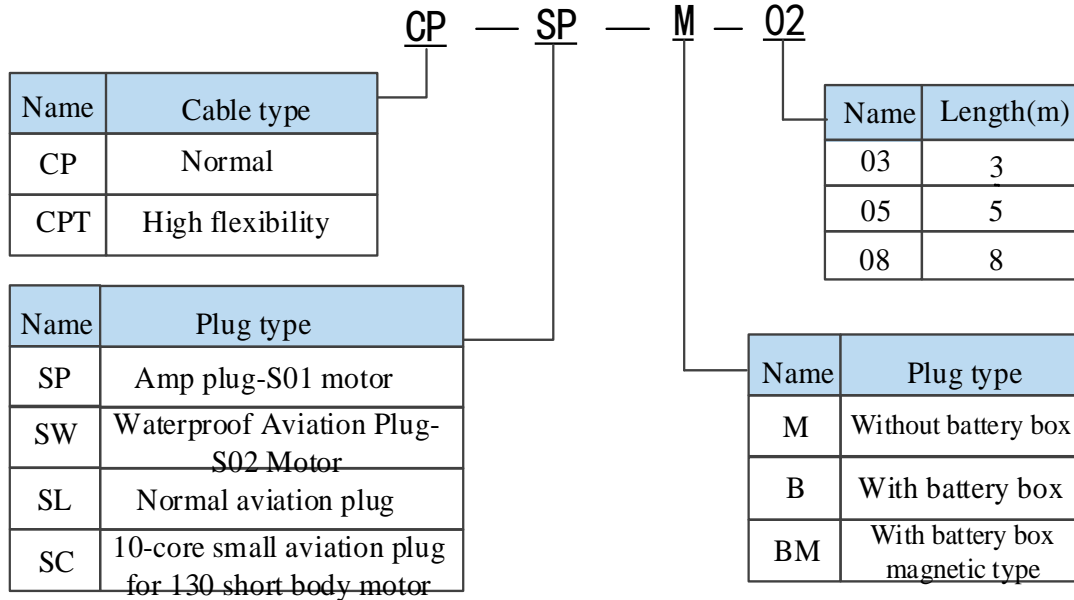

■ Power cable model

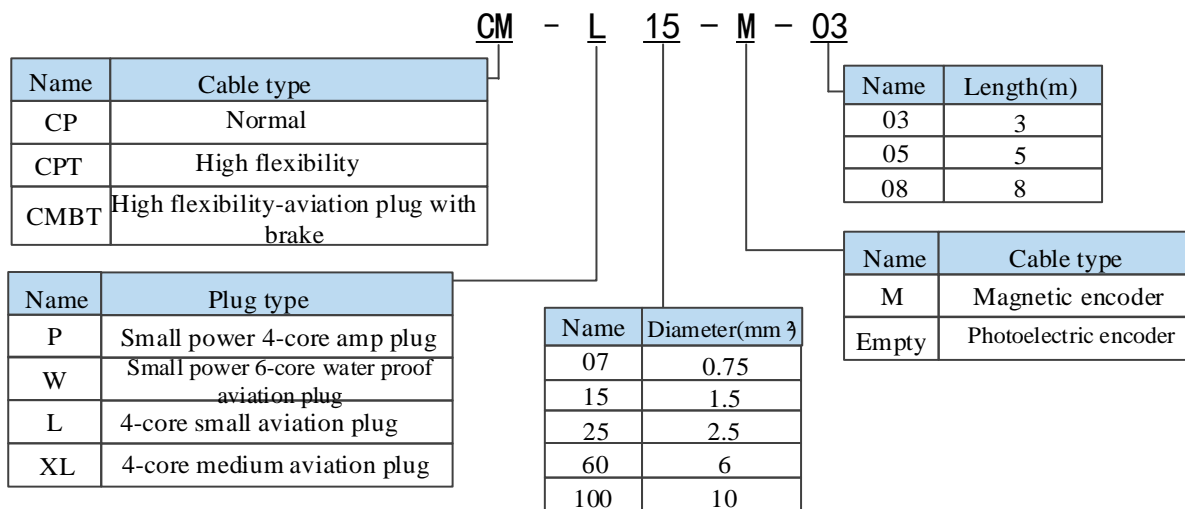

■ Brake cable model

- CB-P03-Length (for 750W and below power motors with motor suffix S01)
- CMBT-W07-M-Length (for 750W and below power motors with motor suffix S02)

1.3.2 Description of each part

■ Encoder cable

(1) Pin definition of encoder on servo driver side

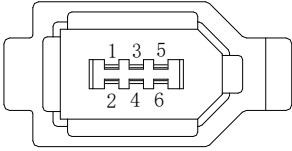
Connector appearance	Pin definition	
	No.	Definition
	1	5V
	2	GND
	3	/
	4	/
	5	485+
	6	485-

(2) Cable connection of encoder on motor side

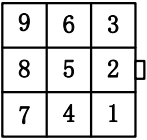
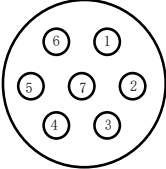
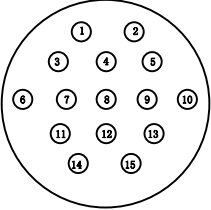
Connector pins	Pin definition		Suitable model
	No.	Definition	
	1	Battery +	40, 60, 80 flange -S01 motor
	2	Battery -	
	3	Shielded cable	
	4	485+	
	5	485-	
	6	/	
	7	5V	
	8	GND	
	9	/	
	No.	Definition	40, 60, 80 flange -S02 motor
	1	Shielded cable	
	2	Battery +	
	3	Battery -	
	4	485+	
	5	485-	
	7	5V	
	8	GND	
	No.	Definition	110 and above flange motor
	1	Shielded cable	
	2	/	
	3	485-	
	4	485+	
	5	/	
	6	GND	
	7	Battery -	
	8	5V	
	9	Battery +	

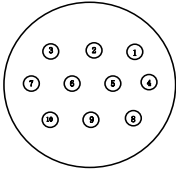
Connector pins	Interface definition		Suitable model
	No.	definition	
	1	/	130 flange medium inertia motor
	2	5V	
	3	GND	
	4	485+	
	5	485-	
	6	Battery +	
	7	Battery -	
	8	/	
	9	/	
	10	Shielded cable	

Battery box description:

1) The encoder including the cable definition of battery +, battery- is for the absolute motor, and the non-absolute motor cable has no such pin.



2) Only the cable of absolute value motor has external battery box, which contains a 3.6V/2.7Ah large capacity battery, and has the function of replacing batteries when power cut.

■ Power cable

(1) Pin definition of power cable on servo driver side

Connector appearance	Pin definition	
	Color	Definition
	Brown	U
	Black	V
	Blue	W
	Yellow-green	PE

(2) Power cable connection on motor side

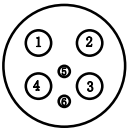
Connector pins	Pin definition		Suitable model
	No.	Definition	
	1	U	40, 60, 80 flange -S01 motor
	2	W	
	3	V	
	4	PE	
	No.	Definition	40, 60, 80 flange -S01 motor brake
	1	BK	
	No.	Definition	750W and below S02 small aviation plug motor
	1	PE	
	2	U	
	3	V	
	4	W	
	5	BK	
6	BK		

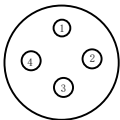
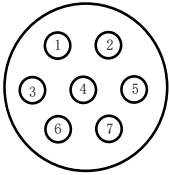
	No.	Definition	110 and above motor (include 130 flange medium inertia motor without brake)
	1	PE	
	2	U	
	3	V	
	4	W	
Connector pins	Interface definition		Suitable model
	No.	Definition	
	1	PE	130 flange medium motor with brake
	2	U	
	3	V	
	4	W	
	5	BK+	
	6	BK-	
	7	/	

Brake pins:

The cable including BK pin is used for the brake motor. The cable of the non-brake motor has no BK pin.